

# **Y3 THREE-PHASE ASYNCHRONOUS MOTOR**



# **Y3** THREE-PHASE ASYNCHRONOUS MOTOR

## **General introduction**

Y3 series three-phase asynchronous motors, developed with new techniques.

Y3 series motors are defined as totally enclosed, fan cooled, squirrel cage type and noted for their novel design, beautiful model, compact structured, low noise, high efficiency, large torque, excellent starting performance, easy serving, etc. The motors are adopted with F class insulation and designed with assessing method for insulation system according to international practice, it enhances greatly have reached an international advanced level of the same kind of products at the initial days of the 90s.

Y3 series motors can be widely used as driving equipments of various machineries, such as machine tools, blowers, pumps, compressors, transporters, agricultural and food processing. Pedestal installation size and centre height and other indexes of the motor completely measured by Y3 series three-phase asynchronous motor.

## **Operating conditions**

Ambient temperature:  $-15^{\circ}\text{C} \sim 40^{\circ}\text{C}$  Altitude: Altitude should be higher than 1000 metres above sea level.

Rated voltage: 380V, 400V, 415V, 440V. Rated frequency: 50Hz, 60Hz. Connection: Y Star-connection for 3kw or less whereas and delta-connection. Duty/Rating: Continuous (S1).

Insulation class: F, the temperature rise of the stator winding is examined at 80K (by resistance method). Protection class: IP55.

Cooling method: IC411.

# TECHNICAL DATA OF Y3 SERIES

**IE1**

NO.	Frame reference and size	Full load current at rated voltage			Rated power		Full load speed in revolutions per minute	Efficiency	Power factor	Direct on line starting torque ratio	Direct on line starting current ratio	Direct on line pull out torque ratio	Mean sound pressure level @1m on no load	Weight	Rotor inertia WK <sup>2</sup>									
		Amps (A)			Power											Speed	EFF.	P.F.	LRT	LRA	BDT	Noise	Weight	J
		380V	400V	415V	kW	HP																		
1	Y3-80M1-2	1.77	1.74	1.68	0.75	1	2840	75.0	0.83	2.2	6.1	2.3	67	16	0.75									
2	Y3-80M2-2	2.61	2.48	2.39	1.1	1.5	2840	76.2	0.84	2.2	6.9	2.3	67	17	0.9									
3	Y3-90S-2	3.46	3.28	3.16	1.5	2	2850	78.5	0.84	2.2	7.0	2.3	72	20	1.2									
4	Y3-90L-2	4.85	4.61	4.45	2.2	3	2855	81.0	0.85	2.2	7.0	2.3	72	23	1.4									
5	Y3-100L-2	6.34	6.03	5.81	3	4	2860	82.6	0.87	2.2	7.5	2.3	76	30	2.9									
6	Y3-112M-2	8.2	7.79	7.51	4	5.5	2880	84.2	0.88	2.2	7.5	2.3	77	41	5.5									
7	Y3-132S1-2	11.1	10.53	10.15	5.5	7.5	2900	85.7	0.88	2.2	7.5	2.3	80	57.5	10.9									
8	Y3-132S2-2	14.9	14.1	13.6	7.5	10	2900	87.0	0.88	2.2	7.5	2.3	80	60.5	12.6									
9	Y3-160M1-2	21.2	20.2	19.5	11	15	2930	88.4	0.89	2.2	7.5	2.3	86	107	37.7									
10	Y3-160M2-2	28.6	27.2	26.2	15	20	2930	89.4	0.89	2.2	7.5	2.3	86	114	49.9									
11	Y3-160L-2	34.7	33.0	31.8	18.5	25	2930	90.0	0.90	2.2	7.5	2.3	86	133	55									
12	Y3-180M-2	41	39.0	37.6	22	30	2940	90.5	0.90	2.0	7.5	2.3	89	165	75									
13	Y3-200L1-2	55.4	52.6	50.7	30	40	2950	91.4	0.90	2.0	7.5	2.3	92	218	124									
14	Y3-200L2-2	67.9	64.5	62.2	37	50	2950	92.0	0.90	2.0	7.5	2.3	92	230	139									
15	Y3-225M-2	82.1	78.0	75.2	45	60	2960	92.5	0.90	2.0	7.5	2.3	92	290	233									
16	Y3-250M-2	100	94.8	91.4	55	75	2970	93.0	0.90	2.0	7.5	2.3	93	359	312									
17	Y3-280S-2	135	129	124	75	100	2975	93.6	0.90	2.0	7.0	2.3	94	475	579									
18	Y3-280M-2	160	152	147	90	125	2975	93.9	0.91	2.0	7.1	2.3	94	510	675									
19	Y3-315S-2	195	186	179	110	150	2975	94.0	0.91	1.8	7.1	2.2	96	875	1180									
20	Y3-315M-2	233	222	214	132	180	2975	94.5	0.91	1.8	7.1	2.2	96	963	1820									
21	Y3-315L1-2	279	265	256	160	220	2975	94.6	0.92	1.8	7.1	2.2	99	1010	2080									
22	Y3-315L2-2	348	331	319	200	270	2975	94.8	0.92	1.8	7.1	2.2	99	1138	2380									
23	Y3-355M-2	433	412	397	250	340	2980	95.2	0.92	1.6	7.1	2.2	103	1900	3000									
24	Y3-355L-2	545	518	499	315	430	2980	95.4	0.92	1.6	7.1	2.2	103	2300	3500									

## TECHNICAL DATA OF Y3 SERIES



NO.	Frame reference and size	Full load current at rated voltage			Rated power		Full load speed in revolutions per minute	Efficiency	Power factor	Direct on line starting torque ratio	Direct on line starting current ratio	Direct on line pull out torque ratio	Mean sound pressure level @1m on no load	Weight	Rotor inertia WK <sup>2</sup>									
		Amps (A)			Power											Speed	EFF.	P.F.	LRT	LRA	BDT	Noise	Weight	J
		380V	400V	415V	kW	HP										r/min	%	cosφ	RLT	RLA	RLT	LwdB(A)	kg	kg·m <sup>2</sup> ·10 <sup>3</sup>
1	Y3-80M1-4	1.57	1.49	1.44	0.55	0.75	1390	71	0.75	2.4	5.2	2.3	58	15	1.8									
2	Y3-80M2-4	2.05	1.95	1.88	0.75	1	1380	73	0.76	2.3	6.0	2.3	58	15.5	2.1									
3	Y3-90S-4	2.85	2.71	2.61	1.1	1.5	1390	76.2	0.77	2.3	6.0	2.3	61	19	2.3									
4	Y3-90L-4	3.72	3.54	3.41	1.5	2	1400	78.5	0.78	2.3	6.0	2.3	61	23	2.7									
5	Y3-100L1-4	5.09	4.90	4.72	2.2	3	1410	80	0.81	2.3	7.0	2.3	64	29	5.4									
6	Y3-100L2-4	6.78	6.39	6.16	3	4	1410	82.6	0.82	2.3	7.0	2.3	64	31	6.7									
7	Y3-112M-4	8.8	8.36	8.06	4	5.5	1435	84.2	0.82	2.3	7.0	2.3	65	42	9.5									
8	Y3-132S-4	11.7	11.2	10.8	5.5	7.5	1440	85.7	0.83	2.3	7.0	2.3	71	63.5	21.4									
9	Y3-132M-4	15.6	14.8	14.3	7.5	10	1450	87	0.84	2.3	7.0	2.3	71	72	29.6									
10	Y3-160M-4	22.5	21.4	20.6	11	15	1460	88.4	0.84	2.2	7.0	2.3	75	110	74.7									
11	Y3-160L-4	30	28.5	27.5	15	20	1460	89.4	0.85	2.2	7.5	2.3	75	129	91.8									
12	Y3-180M-4	36.3	34.5	33.3	18.5	25	1470	90	0.86	2.2	7.5	2.3	76	160	139									
13	Y3-180L-4	43.2	40.8	39.3	22	30	1470	90.5	0.86	2.2	7.5	2.3	76	178	158									
14	Y3-200L-4	57.6	55.1	53.1	30	40	1470	91.4	0.86	2.2	7.2	2.3	79	228	262									
15	Y3-225S-4	70.2	66.7	64.3	37	50	1475	92	0.87	2.2	7.2	2.3	81	288	406									
16	Y3-225M-4	84.9	80.7	77.8	45	60	1475	92.5	0.87	2.2	7.2	2.3	81	313	469									
17	Y3-250M-4	103	98.1	94.6	55	75	1480	93	0.87	2.2	7.2	2.3	83	376	660									
18	Y3-280S-4	138.3	131	127	75	100	1480	93.6	0.88	2.2	6.8	2.3	86	508	1120									
19	Y3-280M-4	165	157	152	90	125	1480	93.9	0.88	2.2	6.8	2.3	86	581	1640									
20	Y3-315S-4	201	191	184	110	150	1480	94.5	0.88	2.1	6.9	2.2	93	846	3100									
21	Y3-315M-4	240	228	220	132	180	1480	94.8	0.88	2.1	6.9	2.2	93	940	3620									
22	Y3-315L1-4	288	273	264	160	220	1480	94.9	0.89	2.1	6.9	2.2	97	1044	4130									
23	Y3-315L2-4	360	342	329	200	270	1480	94.9	0.89	2.1	6.9	2.2	97	1162	4730									
24	Y3-355M-4	443	421	406	250	340	1490	95.2	0.90	2.1	6.9	2.2	101	1700	6500									
25	Y3-355L-4	559	531	511	315	430	1490	95.2	0.90	2.1	6.9	2.2	101	1900	8200									

## TECHNICAL DATA OF Y3 SERIES

IE1

NO.	Frame reference and size	Full load current at rated voltage			Rated power		Full load speed in revolutions per minute	Efficiency	Power factor	Direct on line starting torque ratio	Direct on line starting current ratio	Direct on line pull out torque ratio	Mean sound pressure level @1m on no load	Weight	Rotor inertia WK <sup>2</sup>									
		Amps (A)			Power											Speed	EFF.	P.F.	LRT	LRA	BDT	Noise	Weight	J
		380V	400V	415V	kW	HP																		
1	Y3-80M1-6	1.3	1.23	1.19	0.37	0.5	880	62	0.70	1.9	4.7	2.0	54	15	1.6									
2	Y3-80M2-6	1.8	1.70	1.64	0.55	0.75	880	65	0.72	1.9	4.7	2.1	54	16	1.9									
3	Y3-90S-6	2.29	2.18	2.10	0.75	1	905	69	0.72	2.0	5.3	2.1	57	20	2.9									
4	Y3-90L-6	3.18	3.02	2.91	1.1	1.5	905	72	0.73	2.0	5.5	2.1	57	23	3.5									
5	Y3-100L-6	4	3.80	3.66	1.5	2	920	76	0.75	2.0	5.5	2.1	61	29	6.9									
6	Y3-112M-6	5.6	5.29	5.10	2.2	3	935	79	0.76	2.0	6.5	2.1	65	41	14									
7	Y3-132S-6	7.4	7.03	6.78	3	4	960	81	0.76	2.1	6.5	2.1	69	59	28.6									
8	Y3-132M1-6	9.75	9.26	8.93	4	5.5	960	82	0.76	2.1	6.5	2.1	69	66	35.7									
9	Y3-132M2-6	12.9	12.3	11.8	5.5	7.5	960	84	0.77	2.1	6.5	2.1	69	76.5	44.9									
10	Y3-160M-6	17.2	16.3	15.8	7.5	10	970	86	0.77	2.0	6.5	2.1	73	106	81									
11	Y3-160L-6	24.5	23.3	22.4	11	15	970	87.5	0.78	2.0	6.5	2.1	73	122	116									
12	Y3-180L-6	31.6	30.0	28.9	15	20	970	89	0.81	2.0	7.0	2.1	73	167	207									
13	Y3-200L1-6	38.6	36.6	35.3	18.5	25	980	90	0.81	2.1	7	2.1	76	236	315									
14	Y3-200L2-6	44.7	42.5	41.0	22	30	980	90	0.83	2.0	7	2.1	76	247	360									
15	Y3-225M-6	59.3	56.3	54.3	30	40	980	91.5	0.84	2.0	7	2.1	76	287	547									
16	Y3-250M-6	71	67.5	65.1	37	50	980	92	0.86	2.1	7	2.1	78	355	843									
17	Y3-280S-6	86	81.7	78.1	45	60	980	92.5	0.86	2.1	7	2	80	444	1390									
18	Y3-280M-6	104	99.5	95.9	55	75	980	92.8	0.86	2.1	7	2	80	498	1650									
19	Y3-315S-6	142	135	130	75	100	985	93.5	0.86	2.0	6.7	2	85	859	4110									
20	Y3-315M-6	169	161	155	90	125	985	93.8	0.86	2.0	6.7	2	85	950	4780									
21	Y3-315L1-6	207	196	189	110	150	985	94	0.86	2.0	6.7	2	85	1031	5450									
22	Y3-315L2-6	245	232	224	132	180	985	94.2	0.87	2.0	6.7	2	85	1107	6120									
23	Y3-355M1-6	292	278	268	160	220	990	94.5	0.88	1.9	6.7	2	92	1550	9500									
24	Y3-355M2-6	365	347	335	200	270	990	94.5	0.88	1.9	6.7	2	92	1600	10400									
25	Y3-355L-6	457	434	418	250	340	990	94.5	0.88	1.9	6.7	2	92	1700	12400									

## TECHNICAL DATA OF Y3 SERIES



NO.	Frame reference and size	Full load current at rated voltage			Rated power		Full load speed in revolutions per minute	Efficiency	Power factor	Direct on line starting torque ratio	Direct on line starting current ratio	Direct on line pull out torque ratio	Mean sound pressure level @1m on no load	Weight	Rotor inertia WK <sup>2</sup>									
		Amps (A)			Power											Speed	EFF.	P.F.	LRT	LRA	BDT	Noise	Weight	J
		380V	400V	415V	kW	HP										r/min	%	CosΦ	RLT	RLA	RLT	LwdB(A)	kg	kg·m <sup>2</sup> ·10 <sup>3</sup>
1	Y3-80M1-8	0.88	0.84	0.80	0.18	0.25	645	51	0.61	1.8	3.3	1.9	52	15	2.5									
2	Y3-80M2-8	1.15	1.10	1.06	0.25	0.34	645	54	0.61	1.8	3.3	1.9	52	16	3.0									
3	Y3-90S-8	1.49	1.41	1.36	0.37	0.5	675	62	0.61	1.8	4	1.9	56	20	5.1									
4	Y3-90L-8	2.17	2.07	1.99	0.55	0.75	680	63	0.61	1.8	4	2	56	23	6.5									
5	Y3-100L1-8	2.43	2.31	2.22	0.75	1	680	70	0.67	1.8	4	2	59	29	9.0									
6	Y3-100L2-8	3.36	3.20	3.08	1.1	1.5	680	72	0.69	1.8	5	2	59	31	11.0									
7	Y3-112M-8	4.4	4.18	4.03	1.5	2	690	74	0.70	1.8	5	2	61	41	24.5									
8	Y3-132S-8	6.0	5.66	5.46	2.2	3	710	79	0.71	1.8	6	2	64	61	31.4									
9	Y3-132M-8	7.8	7.41	7.15	3	4	710	80	0.73	1.8	6	2	64	74	39.5									
10	Y3-160M1-8	10.3	9.76	9.41	4	5.5	720	81	0.73	1.9	6	2	68	95.5	75.3									
11	Y3-160M2-8	13.6	12.9	12.5	5.5	7.5	720	83	0.74	1.9	6	2	68	107	93.1									
12	Y3-160L-8	17.8	16.9	16.3	7.5	10	720	85.5	0.75	1.9	6	2	68	128	126									
13	Y3-180L-8	25.5	24.2	23.3	11	15	730	87.5	0.75	2	6.5	2	70	169	203									
14	Y3-200L-8	34.1	32.4	31.2	15	20	730	88	0.76	2	6.6	2	73	236	339									
15	Y3-225S-8	41.1	39.0	37.6	18.5	25	730	90	0.76	1.9	6.6	2	73	274	491									
16	Y3-225M-8	48.9	45.0	43.4	22	30	730	90.5	0.78	1.9	6.6	2	73	290	547									
17	Y3-250M-8	63	60.2	58.1	30	40	735	91	0.79	1.9	6.5	2	75	370	834									
18	Y3-280S-8	78	73.9	71.2	37	50	740	91.5	0.79	1.9	6.6	2	76	488	1650									
19	Y3-280M-8	94	89.4	86.1	45	60	740	92	0.79	1.9	6.6	2	76	563	1930									
20	Y3-315S-8	111	106	102	55	75	735	92.8	0.81	1.8	6.6	2	82	852	4790									
21	Y3-315M-8	150	143	138	75	100	735	93.5	0.81	1.8	6.2	2	82	933	5580									
22	Y3-315L1-8	178	169	163	90	125	735	93.8	0.82	1.8	6.4	2	82	1027	6370									
23	Y3-315L2-8	217	206	199	110	150	735	94	0.82	1.8	6.4	2	82	1117	7230									
24	Y3-355M1-8	261	248	239	132	180	740	93.7	0.82	1.8	6.4	2	90	2000	7900									
25	Y3-355M2-8	315	299	288	160	220	740	94.2	0.82	1.8	6.4	2	90	2150	10300									
26	Y3-355L-8	387	368	355	200	270	740	94.5	0.83	1.8	6.4	2	90	2250	12300									

## TECHNICAL DATA OF Y3 SERIES



NO.	Frame reference and size	Full load current at rated voltage			Rated power		Full load speed in revolutions per minute	Efficiency	Power factor	Direct on line starting torque ratio	Direct on line starting current ratio	Direct on line pull out torque ratio	Mean sound pressure level @1m on no load	Rotor inertia WK <sup>2</sup>								
		Amps (A)			Power										Speed	EFF.	P.F.	LRT	LRA	BDT	Noise	J
		380V	400V	415V	kW	HP									r/min	%	cosφ	RLT	RLA	RLT	LwdB(A)	kg·m <sup>2</sup> ·10 <sup>4</sup>
1	Y3-100L1-10	1.33	1.26	1.22	0.25	0.34	530	55.0	0.52	1.2	3.2	1.7	59	5.7								
2	Y3-100L2-10	1.89	1.80	1.73	0.37	0.5	530	56.0	0.53	1.2	3.2	1.7	59	7.3								
3	Y3-112M1-10	2.50	2.37	2.29	0.55	0.75	540	62.0	0.54	1.2	3.4	1.7	61	10.1								
4	Y3-112M2-10	3.30	3.12	3.01	0.75	1	540	63.0	0.55	1.2	3.4	1.7	61	12.3								
5	Y3-132S-10	4.40	4.20	4.00	1.1	1.5	550	69.0	0.55	1.2	3.6	1.7	64	27.4								
6	Y3-132M-10	5.70	5.50	5.20	1.5	2	565	71.0	0.56	1.2	3.6	1.7	64	35.1								
7	Y3-160M1-10	7.7	7.3	7.1	2.2	3	575	76.0	0.57	1.3	4.0	1.8	68	44.2								
8	Y3-160M2-10	10.2	9.7	9.4	3	4	575	77.0	0.58	1.3	4.0	1.8	68	84.2								
9	Y3-180M-10	12.2	11.5	11.1	4	5.5	580	82.0	0.61	1.3	4.0	1.8	70	104.1								
10	Y3-180L-10	16.2	15.4	14.9	5.5	7.5	580	83.0	0.62	1.3	4.0	1.8	70	140.9								
11	Y3-200L1-10	20.6	19.5	18.8	7.5	10	580	84.0	0.66	1.3	4.5	1.8	73	227								
12	Y3-200L2-10	30.0	28.5	27.5	11	15	580	84.5	0.66	1.3	4.5	1.8	73	379								
13	Y3-225M1-10	39.2	37.2	35.9	15	20	580	85.5	0.68	1.3	4.5	1.8	73	548.9								
14	Y3-250M2-10	48.1	45.7	44.1	18.5	25	580	86.0	0.68	1.3	4.5	1.8	73	611.5								
15	Y3-280S-10	49.9	47.4	45.7	22	30	585	90.5	0.74	1.5	5.2	2.0	76	932.4								
16	Y3-280M1-10	67.7	64.3	62.0	30	40	585	91.0	0.74	1.5	5.2	2.0	76	1844.7								
17	Y3-280M2-10	83.5	79.3	76.5	37	50	585	91.0	0.74	1.5	5.2	2.0	76	2157.7								
18	Y3-315S-10	100	95	91	45	60	590	91.5	0.75	1.5	6.2	2.0	82	5355.2								
19	Y3-315M-10	121	115	111	55	75	590	92.0	0.75	1.5	6.2	2.0	82	6238.4								
20	Y3-315L1-10	162	154	148	75	100	590	92.5	0.76	1.5	5.8	2.0	82	7121.7								
21	Y3-315L2-10	191	181	175	90	125	590	93.0	0.77	1.5	5.9	2.0	82	8083.1								
22	Y3-355M1-10	230	218	211	110	150	590	93.2	0.78	1.5	6.0	2.0	90	10176								
23	Y3-355M2-10	275	261	252	132	180	590	93.5	0.78	1.5	6.0	2.0	90	11515.4								
24	Y3-355L-10	334	317	305	160	220	590	93.5	0.78	1.5	6.0	2.0	90	13751.4								

## TECHNICAL DATA OF Y3 SERIES

IE1

NO.	Frame reference and size	Full load current at rated voltage			Rated power		Full load speed in revolutions per minute	Efficiency	Power factor	Direct on line starting torque ratio	Direct on line starting current ratio	Direct on line pull out torque ratio	Mean sound pressure level @1m on no load	Rotor inertia WK <sup>2</sup>								
		Amps (A)			Power										Speed	EFF.	P.F.	LRT	LRA	BDT	Noise	J
		380V	400V	415V	kW	HP																
1	Y3-100L1-12	1.55	1.47	1.42	0.25	0.34	420	50.0	0.49	1.1	2.8	1.7	59	7.4								
2	Y3-100L2-12	2.21	2.10	2.02	0.37	0.5	425	52.0	0.49	1.1	2.8	1.7	59	10.3								
3	Y3-112M1-12	3.01	2.84	2.74	0.55	0.75	435	57.0	0.49	1.1	3.2	1.7	61	12.6								
4	Y3-132S1-12	3.60	3.40	3.30	0.75	1	440	63.0	0.50	1.1	3.4	1.7	61	28								
5	Y3-132S2-12	5.10	4.90	4.70	1.1	1.5	450	65.0	0.50	1.1	3.4	1.7	64	35.9								
6	Y3-132M-12	6.70	6.30	6.10	1.5	2	460	68.0	0.50	1.1	3.5	1.7	64	45.2								
7	Y3-160M-12	9.0	8.5	8.2	2.2	3	465	74.0	0.50	1.1	4.0	1.8	68	86.1								
8	Y3-160L-12	12.2	11.6	11.2	3	4	470	74.5	0.50	1.1	4.0	1.8	68	106.5								
9	Y3-180L1-12	14.1	13.4	12.9	4	5.5	470	78.0	0.55	1.2	4.0	1.8	70	144.1								
10	Y3-180L2-12	18.5	17.6	16.9	5.5	7.5	475	79.0	0.57	1.2	4.0	1.8	70	232.2								
11	Y3-200L1-12	24.2	23.0	22.2	7.5	10	475	81.0	0.58	1.2	4.5	1.8	73	387.7								
12	Y3-225M1-12	33.1	31.5	30.3	11	15	480	84.0	0.60	1.2	4.5	1.8	73	561.6								
13	Y3-225M2-12	44.7	42.4	40.9	15	20	480	85.0	0.60	1.2	4.5	1.8	73	625.6								
14	Y3-250M-12	53.0	50.3	48.5	18.5	25	480	85.5	0.62	1.2	4.5	1.8	73	953.9								
15	Y3-280S-12	60.0	57.0	55.0	22	30	485	87.0	0.64	1.2	4.5	1.8	76	1887.1								
16	Y3-280M-12	80.1	76.1	73.3	30	40	485	87.5	0.65	1.2	4.5	1.8	76	2207.4								
17	Y3-315S-12	93.2	88.5	85.3	37	50	485	90.0	0.67	1.2	4.5	1.5	76	5478.4								
18	Y3-315M-12	112.8	107.1	103.2	45	60	485	90.5	0.67	1.2	4.5	1.5	82	6381.9								
19	Y3-315L1-12	137.3	130.5	125.8	55	75	485	90.8	0.67	1.2	4.5	1.5	82	7285.5								
20	Y3-315L2-12	186.9	177.6	171.1	75	100	485	91.0	0.67	1.2	4.5	1.5	82	8269.1								
21	Y3-355M1-12	212.3	201.7	194.4	90	125	490	92.0	0.70	1.2	4.5	1.7	82	10410								
22	Y3-355M2-12	258.4	245.4	236.6	110	150	490	92.4	0.70	1.2	4.5	1.7	90	11780.3								
23	Y3-355L-12	309.4	293.9	283.3	132	180	490	92.6	0.70	1.2	4.5	1.7	90	14067.7								



## TECHNICAL DATA OF Y3 SERIES



NO.	Frame reference and size	Full load current at rated voltage			Rated power		Full load speed in revolutions per minute	Efficiency	Power factor	Direct on line starting torque ratio	Direct on line starting current ratio	Direct on line pull out torque ratio	Mean sound pressure level @1m on no load	Rotor inertia WK <sup>2</sup>								
		Amps (A)			Power										Speed	EFF.	P.F.	LRT	LRA	BDT	Noise	J
		380V	400V	415V	kW	HP									r/min	%	cosφ	RLT	RLA	RLT	LwdB(A)	kg·m <sup>2</sup> ·10 <sup>3</sup>
1	Y3-112M1-16	1.52	1.44	1.39	0.25	0.34	310	48.0	0.47	0.9	2.5	1.6	61	28.5								
2	Y3-112M2-16	2.34	2.22	2.14	0.37	0.5	315	48.5	0.47	0.9	2.5	1.6	64	36.6								
3	Y3-132M-16	3.2	3.0	2.9	0.55	0.75	330	54.0	0.48	0.9	2.7	1.6	64	46								
4	Y3-160M1-16	3.8	3.6	3.4	0.75	1	340	62.0	0.48	0.9	2.8	1.6	68	87.7								
5	Y3-160M2-16	5.4	5.1	4.9	1.1	1.5	345	64.0	0.48	0.9	2.8	1.6	68	108.4								
6	Y3-160L-16	7.1	6.7	8.5	1.5	2	345	66.0	0.48	0.9	2.8	1.6	70	146.7								
7	Y3-180M-16	9.4	8.9	8.6	2.2	3	350	71.5	0.49	0.9	3.2	1.6	70	0.2364								
8	Y3-180L-16	12.8	12.1	11.7	3	4	355	72.0	0.49	0.9	3.2	1.6	73	394.8								
9	Y3-200L1-16	16.4	15.6	15.0	4	5.5	355	74.0	0.50	0.9	3.2	1.6	73	571.8								
10	Y3-200L2-16	22.1	21.0	20.2	5.5	7.5	355	75.0	0.50	0.9	3.2	1.6	73	637								
11	Y3-225S-16	28.4	26.9	26.0	7.5	10	360	78.0	0.51	0.9	3.5	1.6	73	971.2								
12	Y3-250M-16	39.4	37.4	35.7	11	15	360	80.0	0.53	0.9	3.5	1.6	76	1921.5								
13	Y3-280M-16	49.8	47.3	45.6	15	20	360	82.0	0.55	1.0	3.5	1.6	76	2247.5								
14	Y3-315S-16	57.6	54.7	52.7	18.5	25	365	86.0	0.56	1.0	3.5	1.6	76	5578.1								
15	Y3-315M-16	68.1	64.6	62.3	22	30	365	87.0	0.56	1.0	3.5	1.6	82	6498.1								
16	Y3-315L1-16	91.7	87.1	83.9	30	40	365	88.0	0.56	1.0	3.5	1.6	82	7418.1								
17	Y3-315L2-16	112	106	102	37	50	365	88.0	0.56	1.0	3.5	1.6	82	8419.5								

## MOUNTING DATA FOR Y3

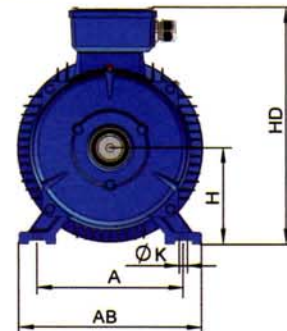
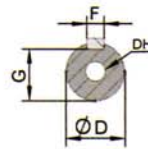
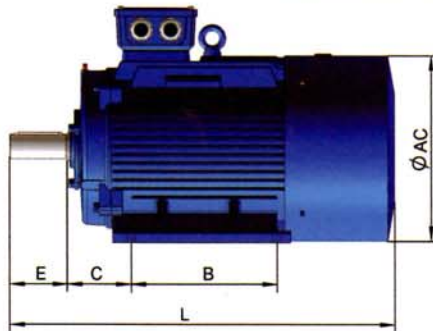
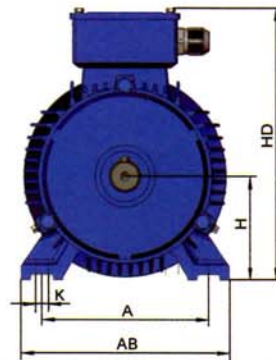
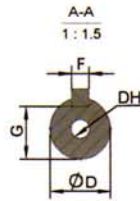
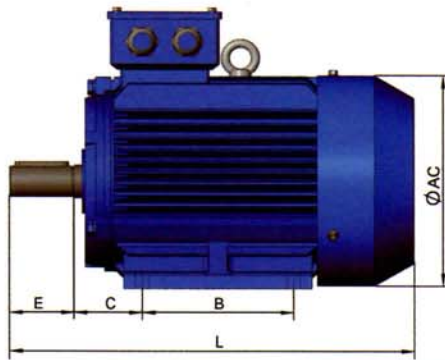

### Frame with feet and end-shield without flange(IM B3)

FRAME SIZE	POLES	A	A/2	B	C	D	E	F	G	H	K	AB	AC	AD	HD	L	DH*
80M	2 4 6 8	125	62.5	100	50	19	40	6	15.5	80	10	165	155	145	220	295	M6X16
90S	2 4 6 8	140	70	100	56	24	50	8	20	90	10	180	175	155	250	320	M8X19
90L	2 4 6 8	140	70	125	56	24	50	8	20	90	10	180	175	155	250	345	M8X19
100L	2 4 6 8	160	80	140	63	28	60	8	24	100	12	205	196	180	270	385	M10X22
112M	2 4 6 8	190	95	140	70	28	60	8	24	112	12	230	220	190	300	400	M10X22
132S	2 4 6 8	216	108	140	89	38	80	10	33	132	12	270	259	210	345	470	M12X28
132M	2 4 6 8	216	108	178	89	38	80	10	33	132	12	270	259	210	345	510	M12X28
160M	2 4 6 8	254	127	210	108	42	110	12	37	160	15	320	315	255	420	615	M16X36
160L	2 4 6 8	254	127	254	108	42	110	12	37	160	15	320	315	255	420	660	M16X36
180M	2 4 6 8	279	139.5	241	121	48	110	14	42.5	180	15	355	355	280	455	700	M16X36
180L	2 4 6 8	279	139.5	279	121	48	110	14	42.5	180	15	355	355	280	455	740	M16X36
200L	2 4 6 8	318	159	305	133	55	110	16	49	200	19	395	397	305	505	770	M20X42
225S	4 8	356	178	286	149	60	140	18	53	225	19	435	445	335	560	815	M20X42
225M	2	356	178	311	149	55	110	16	49	225	19	435	445	335	560	820	M20X42
	4 6 8	356	178	311	149	60	140	18	53	225	19	435	445	335	560	845	M20X42
250M	2	406	203	349	168	60	140	18	53	250	24	490	485	370	615	920	M20X42
	4 6 8	406	203	349	168	65	140	18	58	250	24	490	485	370	615	920	M20X42
280S	2	457	228.5	368	190	65	140	18	58	280	24	550	547	410	680	995	M20X42
	4 6 8	457	228.5	368	190	75	140	20	67.5	280	24	550	547	410	680	995	M20X42
280M	2	457	228.5	419	190	65	140	18	58	280	24	550	547	410	680	1045	M20X42
	4 6 8	457	228.5	419	190	75	140	20	67.5	280	24	550	547	410	680	1045	M20X42
315S	2	508	254	406	216	65	140	18	58	315	28	635	620	530	845	1185	M20X42
	4 6 8 10	508	254	406	216	80	170	22	71	315	28	635	620	530	845	1220	M20X42
315M	2	508	254	457	216	65	140	18	58	315	28	635	620	530	845	1290	M20X42
	4 6 8 10	508	254	457	216	80	170	22	71	315	28	635	620	530	845	1325	M20X42
315L	2	508	254	508	216	65	140	18	58	315	28	635	620	530	845	1290	M20X42
	4 6 8 10	508	254	508	216	80	170	22	71	315	28	635	620	530	845	1325	M20X42
355M	2	610	305	560	254	75	140	20	67.5	355	28	730	698	655	1010	1500	M20X42
	4 6 8 10	610	305	560	254	95	170	25	86	355	28	730	698	655	1010	1530	M20X42
355L	2	610	305	630	254	75	140	20	67.5	355	28	730	698	655	1010	1500	M20X42
	4 6 8 10	610	305	630	254	95	170	25	86	355	28	730	698	655	1010	1530	M20X42

## MOUNTING DATA FOR Y3

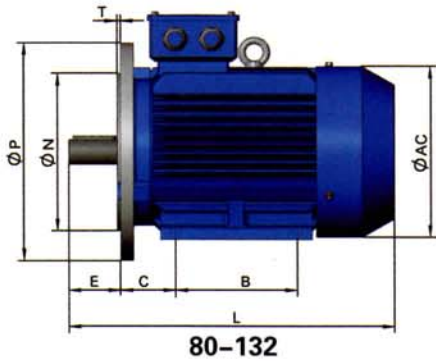

80-132

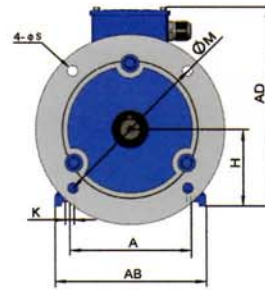
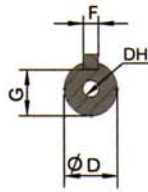

80-132

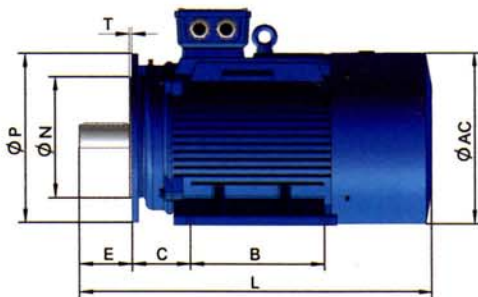

160-355

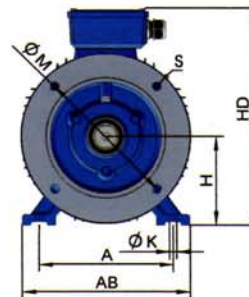
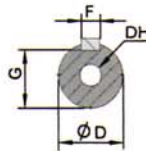

160-355

## FRAME WITH FEET AND END-SHIELD WITH FLANGE(IM B35)

FRAME SIZE	POLES	A	A/2	B	C	D	E	F	G	H	K	M	N	P	S	T	FLANGE HOLES	AB	AC	AD	HD	L	DH*	
80M	2	468	125	62.5	100	50	19	40	6	15.5	80	10	165	130	200	12	3.5	4	165	155	145	220	295	M6X16
90S	2	468	140	70	100	56	24	50	8	20	90	10	165	130	200	12	3.5	4	180	175	155	250	320	M8X19
90L	2	468	140	70	125	56	24	50	8	20	90	10	165	130	200	12	3.5	4	180	175	155	250	345	M8X19
100L	2	468	160	80	140	63	28	60	8	24	100	12	215	180	250	15	4	4	205	196	180	270	385	M10X22
112M	2	468	190	95	140	70	28	60	8	24	112	12	215	180	250	15	4	4	230	220	190	300	400	M10X22
132S	2	468	216	108	140	89	38	80	10	33	132	12	265	230	300	14.5	4	4	270	259	210	345	470	M12X28
132M	2	468	216	108	178	89	38	80	10	33	132	12	265	230	300	14.5	4	4	270	259	210	345	510	M12X28
160M	2	468	254	127	210	108	42	110	12	37	160	15	300	250	350	19	5	4	320	315	255	420	615	M16X36
160L	2	468	254	127	254	108	42	110	12	37	160	15	300	250	350	1	5	4	320	315	255	420	660	M16X36
180M	2	468	279	139.5	241	121	48	110	14	42.5	180	15	300	250	350	19	5	4	355	355	280	455	700	M16X36
180L	2	468	279	139.5	279	121	48	110	14	42.5	180	15	300	250	350	19	5	4	355	355	280	455	740	M16X36
200L	2	468	318	159	305	133	55	110	16	49	200	19	350	250	400	19	5	4	395	397	305	505	770	M20X42
225S	4	468	356	178	286	149	60	140	18	53	225	19	400	300	450	19	5	8	435	445	335	560	815	M20X42
225M	2	468	356	178	311	149	55	110	16	49	225	19	400	350	450	19	5	8	435	445	335	560	520	M20X42
	4	468	356	178	311	149	60	140	18	53	225	19	400	350	450	19	5	8	435	445	335	560	845	M20X42
250M	2	468	406	203	349	168	60	140	18	52.3	250	24	500	350	550	19	5	8	490	485	370	615	920	M20X42
	4	468	406	203	349	168	65	140	18	58	250	24	500	450	550	19	5	8	490	485	370	615	920	M20X42
280S	2	468	457	228.5	358	190	65	140	18	58	280	24	500	450	550	19	5	8	550	547	410	680	995	M20X42
	4	468	457	228.5	358	190	75	140	20	67.5	280	24	500	450	550	19	5	8	550	547	410	680	995	M20X42
280M	2	468	457	228.5	419	190	65	140	18	58	280	24	500	450	550	19	5	8	550	547	410	680	1045	M20X42
	4	468	457	228.5	419	190	75	140	20	67.5	280	24	500	450	550	19	5	8	550	547	410	680	1045	M20X42
315S	2	468	508	254	406	216	65	140	18	58	315	28	600	450	660	24	6	8	635	620	530	845	1185	M20X42
	4	468	508	254	406	216	80	170	22	71	315	28	600	550	660	24	6	8	635	620	530	845	1220	M20X42
315M	2	468	508	254	457	216	65	140	18	58	315	28	600	550	660	24	6	8	635	620	530	845	1290	M20X42
	4	468	508	254	457	216	80	170	22	71	315	28	600	550	660	24	6	8	635	620	530	845	1325	M20X42
315L	2	468	508	254	508	216	65	140	18	58	315	28	600	550	660	24	6	8	635	620	530	845	1290	M20X42
	4	468	508	254	508	216	80	170	22	71	315	28	600	550	660	24	6	8	635	620	530	845	1325	M20X42
355M	2	468	610	305	560	254	75	140	20	67.5	355	28	740	680	800	24	6	8	730	698	655	1010	1500	M20X42
	4	468	610	305	560	254	95	170	25	86	355	28	740	680	800	24	6	8	730	698	655	1010	1530	M20X42
355L	2	468	610	305	630	254	75	140	20	67.5	355	28	740	680	800	24	6	8	730	698	655	1010	1500	M20X42
	4	468	610	305	630	254	95	170	25	86	355	28	740	680	800	24	6	8	730	698	655	1010	1530	M20X42

## MOUNTING DATA FOR Y3

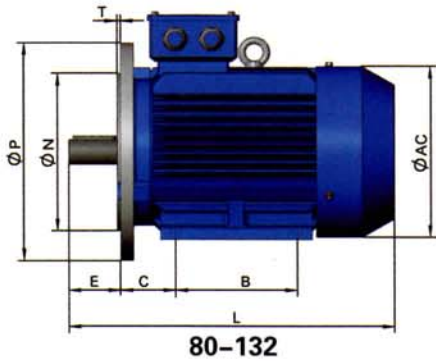

80-132

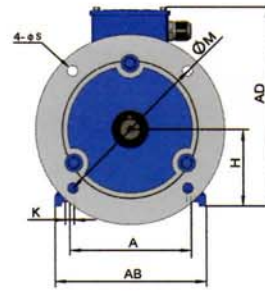
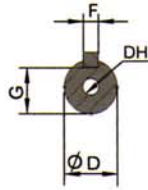

80-132

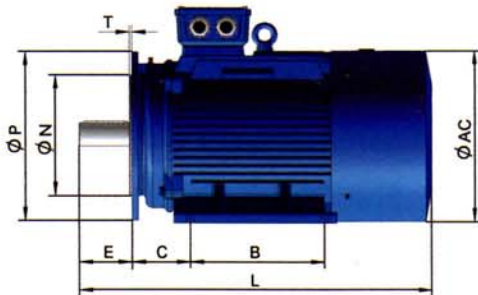

160-355

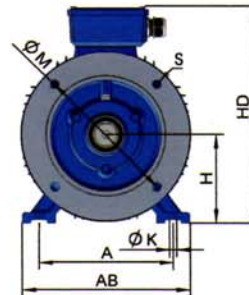
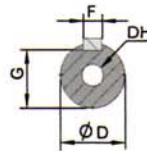

160-355

## FRAME WITH FEET AND END-SHIELD WITH FLANGE(IM B35)

FRAME SIZE	POLES	A	A/2	B	C	D	E	F	G	H	K	M	N	P	S	T	FLANGE HOLES	AB	AC	AD	HD	L	DH*	
80M	2	468	125	62.5	100	50	19	40	6	15.5	80	10	165	130	200	12	3.5	4	165	155	145	220	295	M6X16
90S	2	468	140	70	100	56	24	50	8	20	90	10	165	130	200	12	3.5	4	180	175	155	250	320	M8X19
90L	2	468	140	70	125	56	24	50	8	20	90	10	165	130	200	12	3.5	4	180	175	155	250	345	M8X19
100L	2	468	160	80	140	63	28	60	8	24	100	12	215	180	250	15	4	4	205	196	180	270	385	M10X22
112M	2	468	190	95	140	70	28	60	8	24	112	12	215	180	250	15	4	4	230	220	190	300	400	M10X22
132S	2	468	216	108	140	89	38	80	10	33	132	12	265	230	300	14.5	4	4	270	259	210	345	470	M12X28
132M	2	468	216	108	178	89	38	80	10	33	132	12	265	230	300	14.5	4	4	270	259	210	345	510	M12X28
160M	2	468	254	127	210	108	42	110	12	37	160	15	300	250	350	19	5	4	320	315	255	420	615	M16X36
160L	2	468	254	127	254	108	42	110	12	37	160	15	300	250	350	1	5	4	320	315	255	420	660	M16X36
180M	2	468	279	139.5	241	121	48	110	14	42.5	180	15	300	250	350	19	5	4	355	355	280	455	700	M16X36
180L	2	468	279	139.5	279	121	48	110	14	42.5	180	15	300	250	350	19	5	4	355	355	280	455	740	M16X36
200L	2	468	318	159	305	133	55	110	16	49	200	19	350	250	400	19	5	4	395	397	305	505	770	M20X42
225S	4	468	356	178	286	149	60	140	18	53	225	19	400	300	450	19	5	8	435	445	335	560	815	M20X42
225M	2	468	356	178	311	149	55	110	16	49	225	19	400	350	450	19	5	8	435	445	335	560	520	M20X42
	4	468	356	178	311	149	60	140	18	53	225	19	400	350	450	19	5	8	435	445	335	560	845	M20X42
250M	2	468	406	203	349	168	60	140	18	52.3	250	24	500	350	550	19	5	8	490	485	370	615	920	M20X42
	4	468	406	203	349	168	65	140	18	58	250	24	500	450	550	19	5	8	490	485	370	615	920	M20X42
280S	2	468	457	228.5	358	190	65	140	18	58	280	24	500	450	550	19	5	8	550	547	410	680	995	M20X42
	4	468	457	228.5	358	190	75	140	20	67.5	280	24	500	450	550	19	5	8	550	547	410	680	995	M20X42
280M	2	468	457	228.5	419	190	65	140	18	58	280	24	500	450	550	19	5	8	550	547	410	680	1045	M20X42
	4	468	457	228.5	419	190	75	140	20	67.5	280	24	500	450	550	19	5	8	550	547	410	680	1045	M20X42
315S	2	468	508	254	406	216	65	140	18	58	315	28	600	450	660	24	6	8	635	620	530	845	1185	M20X42
	4	468	508	254	406	216	80	170	22	71	315	28	600	550	660	24	6	8	635	620	530	845	1220	M20X42
315M	2	468	508	254	457	216	65	140	18	58	315	28	600	550	660	24	6	8	635	620	530	845	1290	M20X42
	4	468	508	254	457	216	80	170	22	71	315	28	600	550	660	24	6	8	635	620	530	845	1325	M20X42
315L	2	468	508	254	508	216	65	140	18	58	315	28	600	550	660	24	6	8	635	620	530	845	1290	M20X42
	4	468	508	254	508	216	80	170	22	71	315	28	600	550	660	24	6	8	635	620	530	845	1325	M20X42
355M	2	468	610	305	560	254	75	140	20	67.5	355	28	740	680	800	24	6	8	730	698	655	1010	1500	M20X42
	4	468	610	305	560	254	95	170	25	86	355	28	740	680	800	24	6	8	730	698	655	1010	1530	M20X42
355L	2	468	610	305	630	254	75	140	20	67.5	355	28	740	680	800	24	6	8	730	698	655	1010	1500	M20X42
	4	468	610	305	630	254	95	170	25	86	355	28	740	680	800	24	6	8	730	698	655	1010	1530	M20X42

## MOUNTING DATA FOR Y3

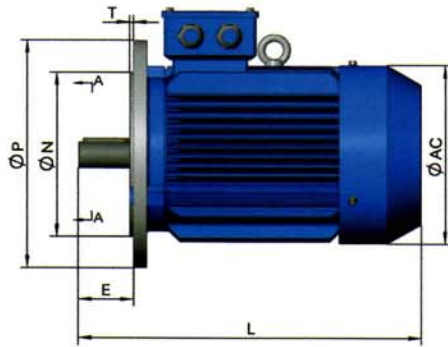

80-132

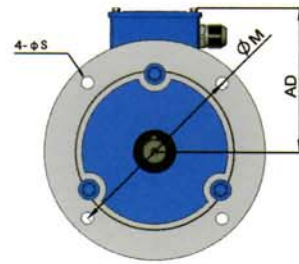
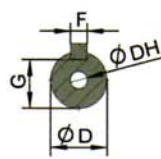

80-132

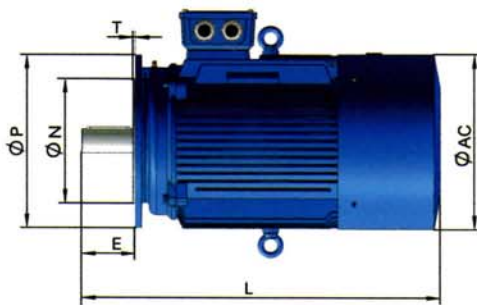

160-355

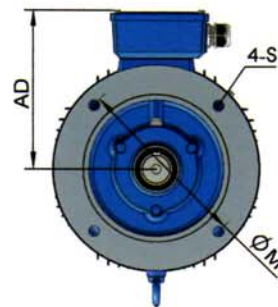
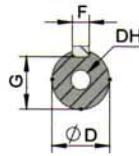

## FRAME WITHOUT FEET AND END-SHIELD WITH FLANGE (IM B5)

FRAME SIZE	POLES	D	E	F	G	M	N	P	S	T	FLANGE HOLES	AC	AD	HF	L	DH*
80M	2 4 6 8	19	40	6	15.5	165	130	200	12	3.5	4	155	145	185	295	M6X16
90S	2 4 6 8	24	50	8	20	165	130	200	12	3.5	4	175	155	195	320	M8X19
90L	2 4 6 8	24	50	8	20	165	130	200	12	3.5	4	175	155	195	345	M8X19
100L	2 4 6 8	28	60	8	24	215	180	250	15	4	4	196	180	245	385	M10X22
112M	2 4 6 8	28	60	8	24	230	180	250	15	4	4	220	190	265	400	M10X22
132S	2 4 6 8	38	80	10	33	265	230	300	15	4	4	259	210	315	470	M12X28
132M	2 4 6 8	38	80	10	33	265	230	300	15	4	4	259	210	315	510	M12X28
160M	2 4 6 8	42	110	12	37	300	250	350	19	5	4	315	255	385	615	M16X36
160L	2 4 6 8	42	110	12	37	300	250	350	19	5	4	315	255	385	660	M16X36
180M	2 4 6 8	48	110	14	42.5	300	250	350	19	5	4	355	280	430	700	M16X36
180L	2 4 6 8	48	110	14	42.5	300	250	350	19	5	4	355	280	430	740	M16X36
200L	2 4 6 8	55	110	16	49	350	300	400	19	5	4	397	305	480	770	M20X42
225S	4 8	60	140	18	53	400	350	450	19	5	8	445	335	535	815	M20X42
225M	2	55	110	16	49	400	350	450	19	5	8	445	335	535	820	M20X42
	4 6 8	60	140	18	53	400	350	450	19	5	8	445	335	535	845	M20X42
250M	2	60	140	18	53	500	450	550	19	5	8	485	370	595	920	M20X42
	4 6 8	65	140	18	58	500	450	550	19	5	8	485	370	595	920	M20X42
280S	2	65	140	18	58	500	450	550	19	5	8	547	410	650	995	M20X42
	4 6 8	75	140	20	67.5	500	450	550	19	5	8	547	410	650	995	M20X42
280M	2	65	140	18	58	500	450	550	19	5	8	547	410	650	1045	M20X42
	4 6 8	75	140	20	67.5	500	450	550	19	5	8	547	410	650	1045	M20X42

## MOUNTING DATA FOR Y3

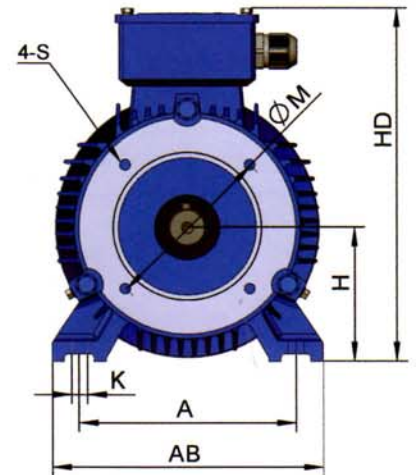
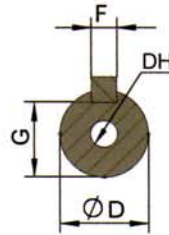
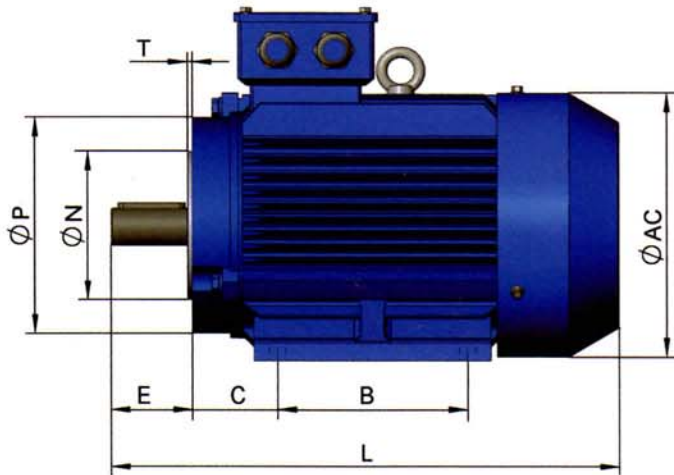

80-132

80-132

## FRAME WITH FEET AND END-SHIELD WITH FLANGE (IM B34)

FRAME SIZE	POLES	A	A/2	B	C	D	E	F	G	H	K	M	N	P	R*	S	T	FLANGE HOLES	AB	AC	AD	HD	L
80	2 4 6 8	125	62.5	100	50	19	40	6	15.5	80	10	100	80	120	0	M6	3.0	4	165	155	145	214	295
90S	2 4 6 8	140	70	100	56	24	50	8	20	90	10	115	95	140	0	M8	3.0	4	180	175	155	250	320
90L	2 4 6 8	140	70	125	56	24	50	8	20	90	10	115	95	140	0	M8	3.0	4	180	175	155	250	345
100L	2 4 6 8	160	80	140	63	28	60	8	24	100	12	130	110	160	0	M8	3.5	4	205	196	180	270	385
112M	2 4 6 8	190	95	140	70	28	60	8	24	112	12	130	110	160	0	M8	4	4	230	220	190	300	400
132S	2 4 6 8	216	108	140	89	38	80	10	33	132	12	165	130	200	0	M10	4	4	270	259	210	345	470
132M	2 4 6 8	216	108	178	89	38	80	10	33	132	12	165	130	200	0	M10	4	4	270	259	210	345	510

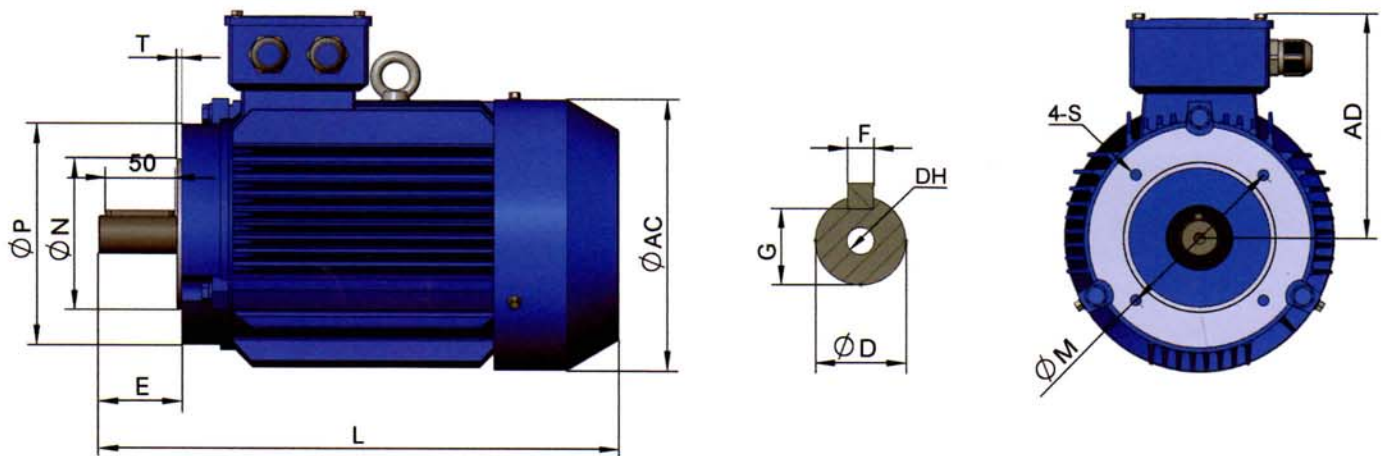

## MOUNTING DATA FOR Y3

FRAME WITHOUT FEET AND END-SHIELD WITHOUT FLANGE (IM B14)

FRAME SIZE	POLES	D	E	F	G	M	N	P	R*	S	T	FLANGE HOLES	AC	AD	HF	L
80	2 4 6 8	19	40	6	15.5	100	80	120	0	M6	3.0	4	155	145	185	295
90S	2 4 6 8	24	50	8	20	115	95	140	0	M8	3.0	4	175	155	195	320
90L	2 4 6 8	24	50	8	20	115	95	140	0	M8	3.0	4	175	155	195	345
100L	2 4 6 8	28	60	8	24	130	110	160	0	M8	3.5	4	196	180	245	385
112M	2 4 6 8	28	60	8	24	130	110	160	0	M8	3.5	4	220	190	265	400
132S	2 4 6 8	38	80	10	33	165	130	200	0	M10	3.5	4	259	210	315	470
132M	2 4 6 8	38	80	10	33	165	130	200	0	M10	3.5	4	259	210	315	510

## FRAME TYPE, FRAME WITHOUT FEET AND END SHIELD WITH FLANGE (WITH PLAIN HOLES) (IM V1)

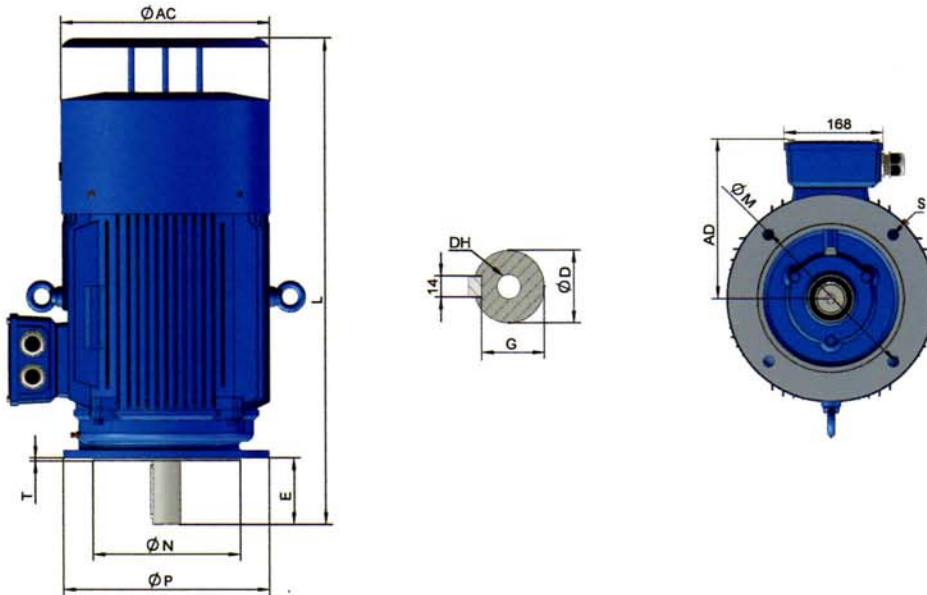

FRAME SIZE	POLES	D	E	F	M	N	P	S	T	FLANGE HOLES	AC	AD	HF	L
160M	2 4 6 8	42	110	12	300	250	350	19	5	4	315	255	455	695
160L	2 4 6 8	42	110	12	300	250	350	19	5	4	315	255	455	740
180M	2 4 6 8	48	110	14	300	250	350	19	5	4	355	280	500	790
180L	2 4 6 8	48	110	14	300	250	350	19	5	4	355	280	500	830
200L	2 4 6 8	55	110	16	350	300	400	19	5	4	397	305	550	860
225S	4 8	60	140	18	400	350	450	19	5	8	445	335	610	905
225M	2	55	110	16	400	350	450	19	5	8	445	335	610	910
	4 6 8	60	140	18	400	350	450	19	5	8	445	335	610	935
250M	2	60	140	18	500	450	550	19	5	8	485	370	650	1015
	4 6 8	65	140	18	500	450	550	19	5	8	485	370	650	1015
280S	2	65	140	18	500	450	550	19	5	8	547	410	720	1110
	4 6 8	75	140	20	500	450	550	19	5	8	547	410	720	1110
280M	2	65	140	18	500	450	550	19	5	8	547	410	720	1150
	4 6 8	75	140	20	500	450	550	19	5	8	547	410	900	1150
315S	2	65	140	18	600	550	660	24	6	8	620	530	900	1280
	4 6 8 10	80	170	22	600	550	660	24	6	8	620	530	900	1310
315M	2	65	140	18	600	550	660	24	6	8	620	530	900	1380
	4 6 8 10	80	170	22	600	550	660	24	6	8	620	530	900	1430
315L	2	65	140	18	600	550	660	24	6	8	620	530	900	1380
	4 6 8 10	80	170	22	600	550	660	24	6	8	620	530	900	1430
355M	2	75	140	20	740	680	800	24	6	8	698	655	1010	1640
	4 6 8 10	95	170	25	740	680	800	24	6	8	698	655	1010	1670
355L	2	75	140	20	740	680	800	24	6	8	698	655	1010	1640
	4 6 8 10	95	170	25	740	680	800	24	6	8	698	655	1010	1670



## IM B3 H400-450

### MOUNTING AND OVERALL DIMENSIONS OF IM B3 H400-450

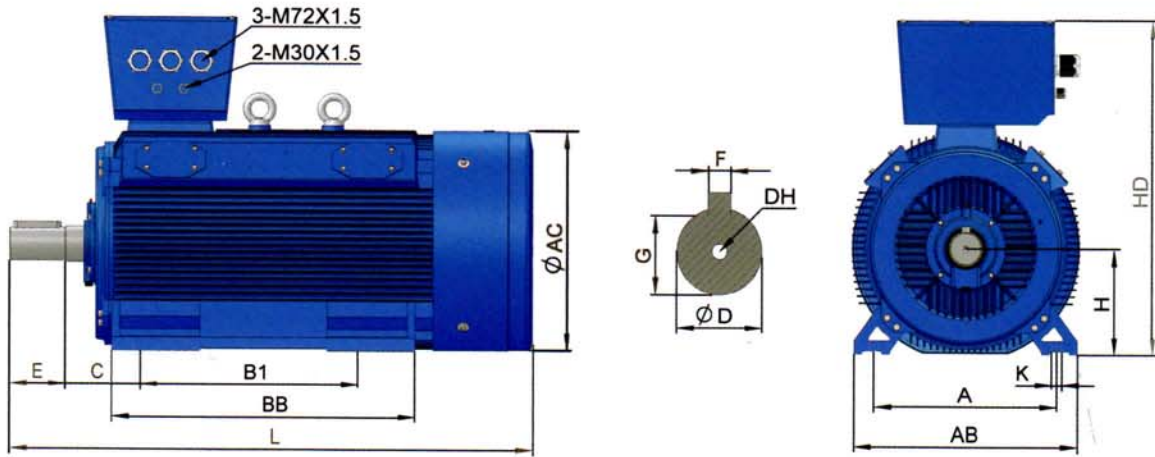

Type	Mounting Dimensions										Overall Dimensions													
	Poles	A	AA	AB	AC	B1	BB	C	D	DH	E	F	G	H	HA	HD	K	L	AD	Eyeboit	X	Y	Z	
400L	4								$\phi 110$		210	28	100					1925						
400L	6/8/10	686	125	810	855	710	1090	280	$\phi 120$	M24X54	210	32	109	400	30	1080	$\phi 36$	1925	430	2xM36	430	540	225	
450L	4								$\phi 130$		210	32	119					2200						
450L	4/6/8/10	800	190	1000	930	1000	1300	300	$\phi 140$	M24X54	210	32	129	450	52	1380	$\phi 42$	2200	480	2xM36	500	595	410	

## IM B35 H400-450

### MOUNTING AND OVERALL DIMENSIONS OF IM B35 H400-450

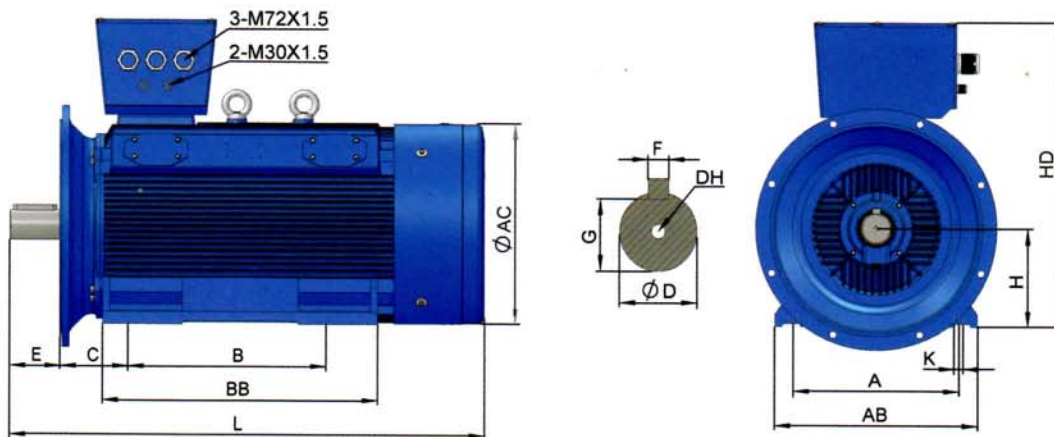

Type	Mounting Dimensions															Overall Dimensions										
	Poles	A	AA	AB	AC	B1	BB	C	D	E	F	H	HA	HD	DH	K	L	M	N	P	S	T	Eyeboit	X	Y	Z
400L	4								$\phi 110$	210	28						1925									
400L	6/8/10	686	125	810	855	710	1090	280	$\phi 120$	210	28	400	30	1080	M24X54	$\phi 36$	1925	940	880	1000	8x $\phi 28$	6	2xM36	430	540	225
450L	4	800	190	1000	930	1000	1300	300	$\phi 130$	210	32	450	52	1380		$\phi 42$	2200	1080	1000	1150	8x $\phi 28$	6	2xM36	500	595	410
450L	6/8/10								$\phi 140$	210	32				M24X54		2200									

## IM V1 H400-450 MOUNTING AND OVERALL DIMENSIONS OF

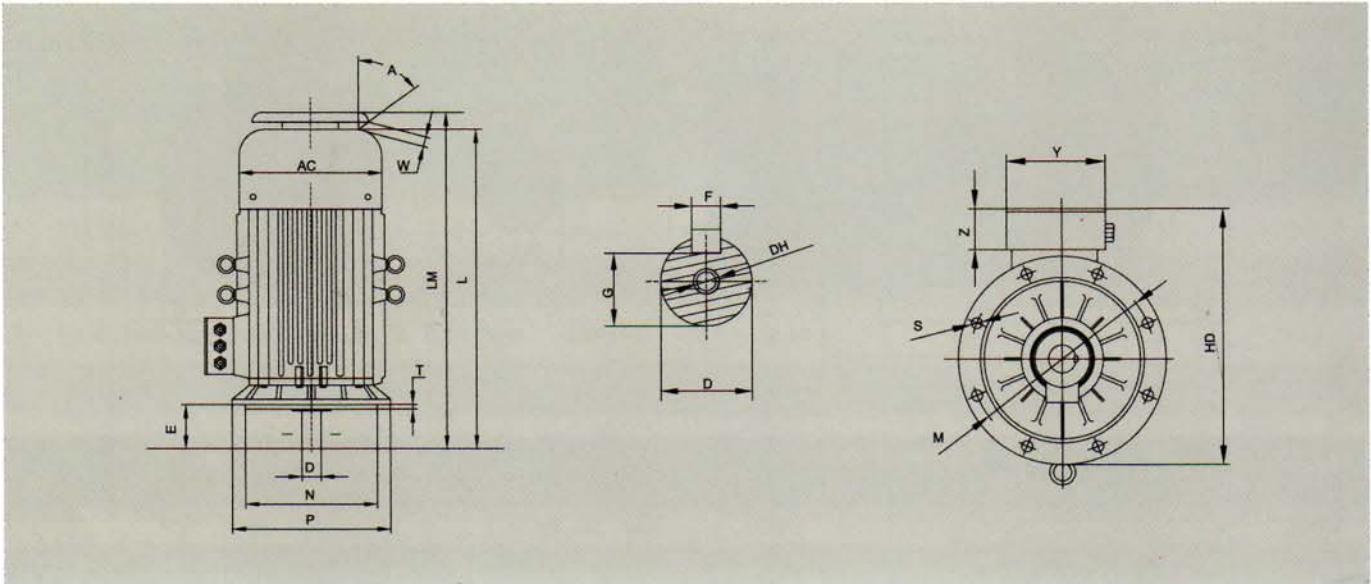

Type	Mounting Dimensions										Overall Dimensions									
	Poles	AC	D	E	F	G	H	HD	DH	L	LM	M	N	P	S	T	Eyeboit	X	Y	Z
400L	4		φ 110	210	28	100				1925	2025									
400L	6、8、10	855	φ 120	210	28	100	400	1180	M24X54	1925	2025	940	880	1000	8x φ 28	6	4xM36	430	540	225
450L	4	930	φ 130	210	32	119	450	1380		2200	2300	1080	1000	1150	8x φ 28	6	4xM36	500	595	410
450L	6、8、10		φ 140	210	32	129			M24X54	2200	2300									

## TECHNICAL DATA OF H400-450 SERIES

	Frame reference and size	Rated power	Full load current at rated voltage	Full load speed in revolutions per minute	Efficiency	Power factor	Direct on line starting torque ratio	Direct on line starting current ratio	Direct on line pull out torque ratio	Mean sound pressure level @1m on no load	Voltage
NO.	Type	Output kW	Amps A	Speed r/min	EFF. %	P.F. Cos φ	LRT/RLT	LRA/RLA	BDT/RLT	Noise LwdB(A)	V
1	400L1-4	450	792	1490	96.3	0.89	1.7	6.8	2.2	105	380
2	400L2-4	500	878	1490	96.3	0.89	1.7	6.8	2.2	105	380
3	400L3-4	560	978	1490	96.3	0.89	1.7	6.8	2.2	108	380

## TECHNICAL DATA OF H400-450 SERIES

	Frame reference and size	Rated power	Full load current at rated voltage	Full load speed in revolutions per minute	Efficiency	Power factor	Direct on ine starting torque ratio	Direct on line starting current ratio	Direct on line pull out torque ratio	Mean sound pressure level @1m on no load	Voltage
NO.	Type	Output kW	Amps A	Speed r/min	EFF. %	P.F. Cos $\phi$	LRT RLT	LRA RLA	BDT RLT	Noise LwdB(A)	V
4	400L4-4	630	633	1490	96.3	0.89	1.7	6.8	2.2	108	660
5	450L1-4	630	639	1490	96.5	0.89	1.6	7	2.6	108	660
6	450L2-4	710	718	1490	96.5	0.89	1.6	7	2.6	108	660
7	450L3-4	800	806	1490	96.7	0.89	1.6	7	2.6	108	660
8	450L4-4	900	905	1490	96.7	0.89	1.6	7	2.6	108	660
9	400L1-6	355	649	990	96	0.86	2	6.5	2.2	98	380
10	400L2-6	400	729	990	96	0.86	2	6.5	2.2	98	380
11	400L3-6	450	817	990	96	0.86	2	6.5	2.2	102	380
12	400L4-6	500	906	990	96	0.86	2	6.5	2.2	102	380
13	450L1-6	500	534	990	96.2	0.86	1.6	7	2.6	102	660
14	450L2-6	560	596	990	96.3	0.85	1.6	7	2.6	105	660
15	450L3-6	630	670	990	96.5	0.85	1.6	7	2.6	105	660
16	450L4-6	710	751	990	96.5	0.85	1.6	7	2.6	105	660
17	400L1-8	315	596	740	96	0.82	2.1	6.1	2.4	95	380
18	400L2-8	355	676	740	96	0.82	2.1	6.1	2.4	95	380
19	400L3-8	400	757	740	96	0.82	2.1	6.1	2.4	99	380
20	450L1-8	400	445	740	96	0.89	1.6	7	2.6	99	380
21	450L2-8	450	499	740	96	0.82	1.6	7	2.6	99	380
22	450L3-8	500	553	740	96.2	0.82	1.6	7	2.6	99	380
23	450L4-8	560	621	740	96.2	0.82	1.6	7	2.6	102	380
24	400L1-10	250	512	590	95.2	0.77	2.1	6.5	2.4	99	660
25	400L2-10	315	639	590	96	0.77	2.1	6.5	2.4	99	660
26	400L3-10	355	718	590	96	0.77	2.1	6.5	2.4	99	660
27	450L1-10	355	732	590	95.6	0.77	1.6	7	2.6	99	660
28	450L2-10	400	822	590	95.6	0.77	1.6	7	2.6	99	660
29	450L3-10	450	927	590	95.6	0.77	1.6	7	2.6	99	660